

22 Evolution AR15 .22LR Conversion

The CMMG 22 Evolution AR15 .22 LR conversion is a .22 LR caliber recoil operated sub-caliber device which replaces the standard bolt carrier assembly in the AR15 family of firearms. It allows the use of inexpensive .22LR ammunition in place of 5.56x45mm ammunition.

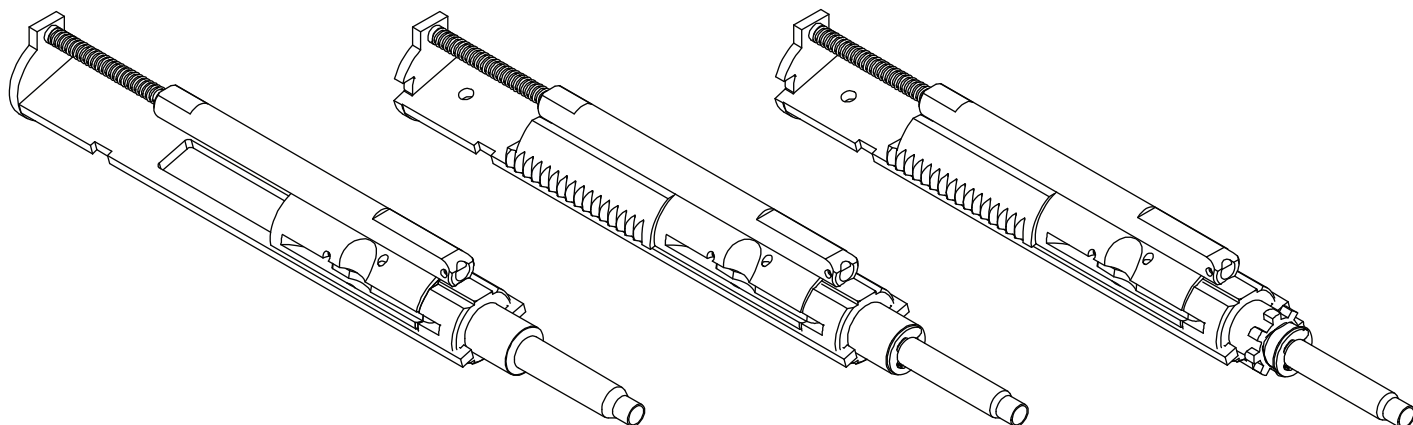

CMMG's 22 Evolution line of .22 LR conversions are available in a number of configurations, such as left and right hand versions and parkerized and stainless steel finishes. Available accessories include forward assist adapters, a bolt hold open adapter, an anti jam charging handle, a chamber bushing and lock, along with 10, 15 and 25 round magazines. Contact your local retailer or CMMG directly for all replacement parts, upgrades and accessories

Installation Instructions

1. Make sure the firearm is completely unloaded and safe.
2. Break open the firearm by pushing the rear take down pin through.
3. Remove the 5.56x45mm Bolt Carrier Group and check that the bore is clear of any obstructions.
4. With the charging handle approximately half way out(fig. 2), Insert the conversion unit in the upper receiver until the rear of the conversion bolt is flush with rear of the upper receiver.
5. Close the receivers and insert the take down pin.
6. Hand cycle the action checking for any resistance in the action.

The firearm should at this point be ready accept the .22LR magazine and commence shooting.

Operation Instructions

When chambering a new cartridge, manually pull the charging handle fully to the rear and completely release the charging handle. DO NOT hold (ride) the handle as the bolt closes. This can cause a slow-feed situation that can result in a failure to feed, or cause the bolt to not fully close.

Once loaded operation is the same as the host firearm. The bolt catch and forward assist will not function unless the conversion is equipped with bolt hold open actuator and forward assist adapter. These adapters are available for purchase if the conversion is not originally equipped with the parts.

The unit was successfully factory test fired with Federal High Velocity 36 grain Copper Plated Hollow Point ammunition. This type of ammo is recommended for insured performance along with most similar quality ammo. Light and subsonic ammunition will not operate as reliably(if at all) as the heavier high velocity ammunition.

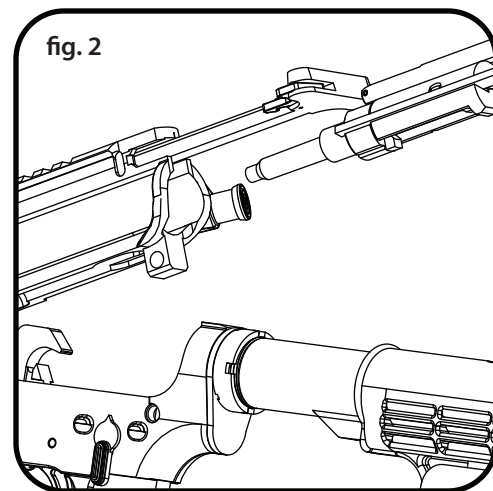

Cleaning and Maintenance Instructions

All components of the .22 conversion until as well as the host rifle should be cleaned and lubricated before and after each use. To clean the unit hold the bolt to the rear while using a brush to clean the bolt and chamber adapter faces. Use a bore brush on the chamber adapter (fig. 3). We recommend using a drill in combination with a bore brush and cleaning rod section to thoroughly clean and polish the inside of the chamber adapter. While spinning the brush move it in and out of the chamber adapter, keeping it flushed with oil or solvent until the chamber adapter is warm to the touch.

Use a soft rag and cleaning solvent, wipe clean the rest of the conversion and relubricate all metal to metal contact surfaces along with the exterior of the chamber adapter. The bolt should move smoothly and evenly on the receiver rails. Check both the firing pin and extractor to make sure they move freely, they may be removed for cleaning.

Do not disassemble this .22 conversion kit, specifically the chamber adapter and receiver rail, damage to the precise alignment of the receiver rails may result due to improper disassembly/assembly. The conversion should be removed from the firearm at least every 500 rounds to clean and lube the chamber and bolt locking lug area of the barrel. This requires the standard chamber/locking lugs cleaning brush and bore brush. Firing the 5.56x45 mm cartridge will fully clean any residual .22LR lead fouling from the gas tube and gas port. It is recommended that copper plated ammunition be used to reduce lead fouling.

Tips, Tricks and Notes

For best results do not use a notched hammer (fig. 4).

Remington brand ammunition may not function reliably in the conversion.

Remove the protective green cap from the chamber adapter prior to use.

Underload the magazine at first until the magazine becomes easier to load.

Allow a break-in period of approximately hundred rounds before installing the BHOA.

Slight bulging around the rim opposite of the firing pin strike on fired cases is normal.

Do not leave the conversion bolt in the firearm after shooting, remove it immediately.

The conversion is not compatible with Precision Reflex's Gas buster charging handle.

Do not disassemble the chamber adapter/receiver plate

Warranty

CMMG will cover the .22 conversion against manufacturer's defects for the lifetime of the product.

Statement of Liability:

This device is classified as a FIREARM ACCESSORY and is surrendered by use with the express understanding that we assume NO LIABILITY for its resale or safe handling under the local laws and regulations.

CMMG, Inc. assumes no responsibility for

1. Damage to the firearm in which the conversion is installed.
2. Physical injury or property damage resulting from intentional or accidental discharge.
3. The function of any device subjected to influences beyond their control.

Further, CMMG, Inc. will honor no claims which may result from careless handling, unauthorized adjustments, alterations, modifications, defective or improper ammunition, corrosion, neglect or condition of the firearm in which it is installed. The receipt and use of this product implies understanding of, agreement with and acceptance of this statement of liability.

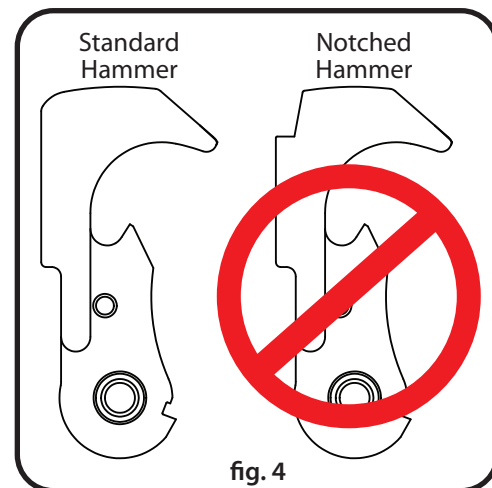
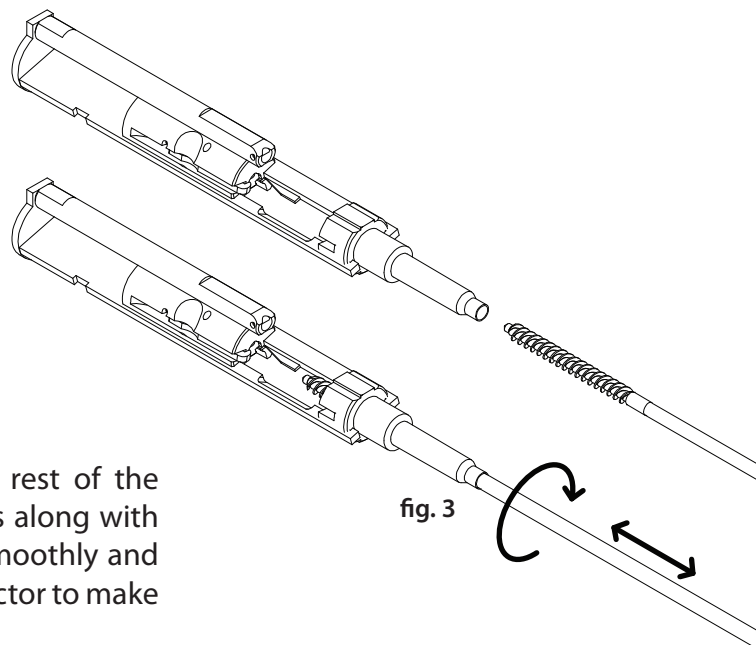

BHOA Installation Instructions

Insert the bolt hold open actuator assembly into the lower receiver from the top making sure the tab on the bolt catch fits into the slot on the bolt catch actuator (fig. 5). Insert a magazine to ensure proper fore and aft positioning of the BHOA housing. Install the upper receiver normally. Use the actuator adjustment screw (fig. 6) to adjust the height of the actuator so that the actuator is as close to the bolt as possible without interfering with normal operation of the bolt.

With the bolt to the rear press the bolt catch release to test that the bolt catch actuator moves freely without binding. Insert an empty magazine on a closed bolt and charge the bolt making sure it locks to the rear and remains locked to the rear when the magazine is removed. Press the bolt catch release to test that the bolt is released when pressed.

Magazine Instructions

The magazine may not fit all lower receivers, for the best fit file, sand or shave the indicated boss (fig. 7) on both halves until the desired fit is achieved.

CMMG recommends loading the magazine by pushing down with the round just in front of the feed lips and then rotating the round down and to the rear (fig. 8). Loading the magazine in this manner will help prevent wear and tear on the magazine's feed lips.

For maximum service life of the BHOA compatible CMMG magazines, CMMG recommends only loading 15-20 rounds in the magazine. The magazine will accept up to 25 rounds, but this can reduce the service life of the magazine. The standard green follower magazines can be loaded to the 25 round capacity without reducing the service life.

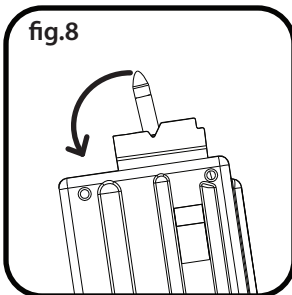
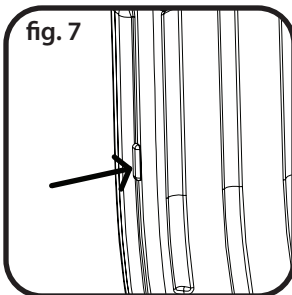
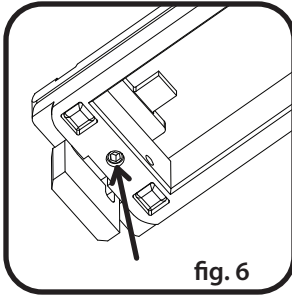
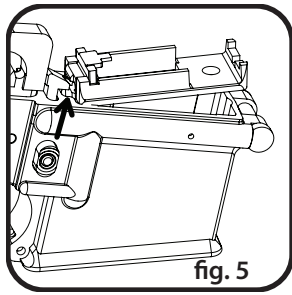

BHOA Follower Installation

To install the bolt hold open actuator compatible follower assembly, align the follower with the magazine's cavity and compress the upper and lower followers together to insert the assembly in the magazine body (fig. 9).

Spring and Floor Plate Installation

Insert the magazine spring after the follower assembly. Fit the floor plate retention piece in the retention coil and install the floor plate (fig. 10). When loading the magazine for the first time, only load 10-15 rounds. Continue only loading 10-15 rounds until the magazine becomes easier to load. Increase the number of rounds loaded as the magazine becomes easier to load. Total loaded round count should be about 25 rounds. Some magazines may need fitting on the inside of the magazine body to insure the follower can move smoothly throughout the range of movement, loosening the top and rear screws holding the magazine halves together may also improve the follower's freedom of motion.

Magazine Internals Exploded Diagram

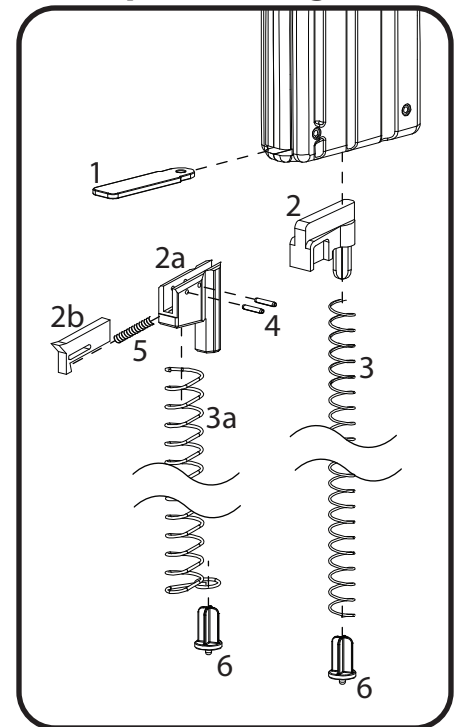

1. Floor Plate
2. Follower
 - a. BHOA Lower Follower
 - b. BHOA Upper Follower
3. Magazine Spring
 - a. BHOA Magazine Spring
4. BHOA Follower Roll Pins
5. BHOA Expansion Spring
6. Floor Plate Retainer

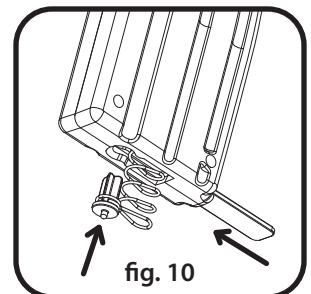
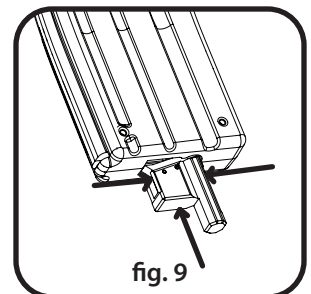

EXPLODED DIAGRAM

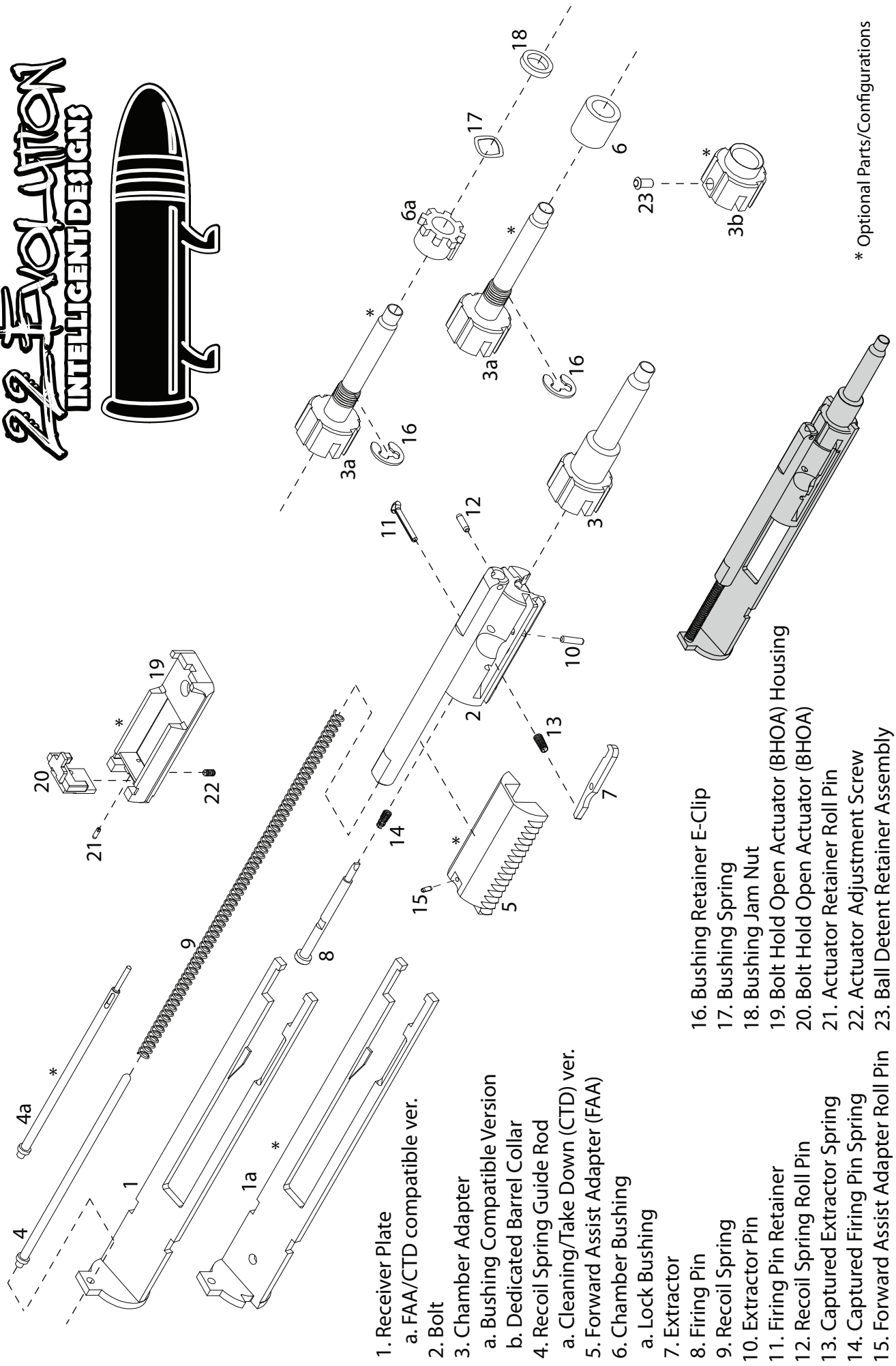
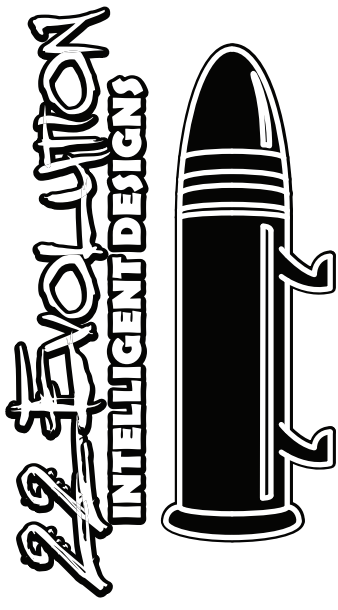

- 1. Receiver Plate
 - a. FAA/CTD compatible ver.
- 2. Bolt
- 3. Chamber Adapter
 - a. Bushing Compatible Version
 - b. Dedicated Barrel Collar
- 4. Recoil Spring Guide Rod
 - a. Cleaning/Take Down (CTD) ver.
- 5. Forward Assist Adapter (FAA)
- 6. Chamber Bushing
 - a. Lock Bushing
- 7. Extractor
- 8. Firing Pin
- 9. Recoil Spring
- 10. Extractor Pin
- 11. Firing Pin Retainer
- 12. Recoil Spring Roll Pin
- 13. Captured Extractor Spring
- 14. Captured Firing Pin Spring
- 15. Forward Assist Adapter Roll Pin
- 16. Bushing Retainer E-Clip
- 17. Bushing Spring
- 18. Bushing Jam Nut
- 19. Bolt Hold Open Actuator (BHOA) Housing
- 20. Bolt Hold Open Actuator (BHOA)
- 21. Actuator Retainer Roll Pin
- 22. Actuator Adjustment Screw
- 23. Ball Detent Retainer Assembly

* Optional Parts/Configurations